

Rev.	ECN Number	Description	Date	Drawn	Checkd	Approved

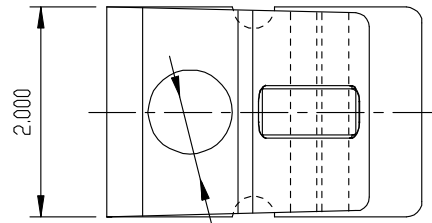

∅0.80吸盘位置

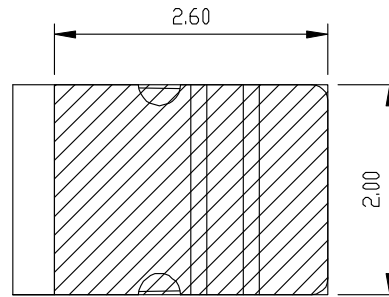
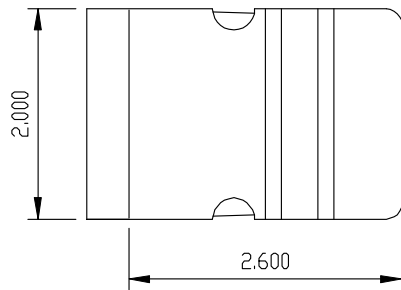
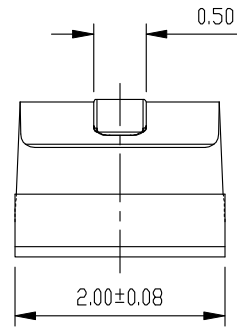
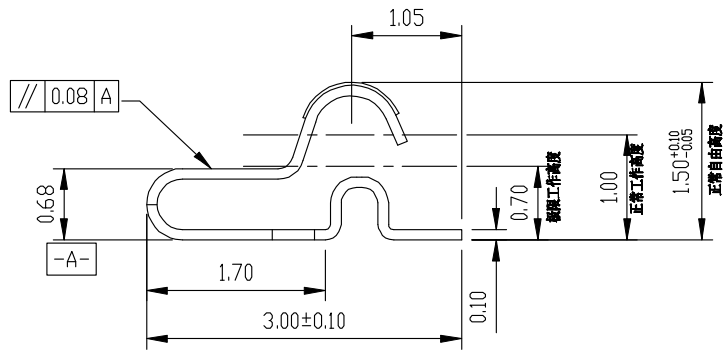

焊盘尺寸

尺寸公差 ±0.05

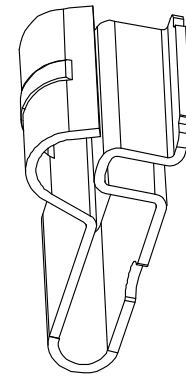

3D 图

技术要求:

- 1.材质:不锈钢SUS301, T=0.10±0.005;
- 2.端子锡脚焊接面和接触面不可有毛边,其他部位毛边最大0.03mm;
- 3.扭曲:45°/1000mm,拱形 5mm/1000mm;
- 4.标示有“▼”符号的为重点控制和检验尺寸;
- 5.未标注之R MAX R0.13;
- 6.电镀须满足48小时盐雾测试;
- 7.寿命测试>2万次,产品弹力要求在60gf~80gf之间
- 8.镍底50~80u"min,产品外表面镀全金1U"MIN

LANGDUN

GENERAL TOLERANCE	
XX. ±0.50	/
X. ±0.35	
.X ±0.25	
.XX ±0.15	

SCALE:	1:1
UNIT:	mm
SIZE:	A4

DRAWN	DATE	DWG. NO.
CHECK	DATE	
APPROVE	DATE	

PARTS NO.(INTENDED USE)	AS-014
-------------------------	--------

TITLE	客户图
	S4 Spring,SMT, B type
	L3.0*W2.0*H1.50mm

REV.	A
SHEET	1/1